

Specifications

U9-HK-84 & U9-HK-120 HOOK HOISTS

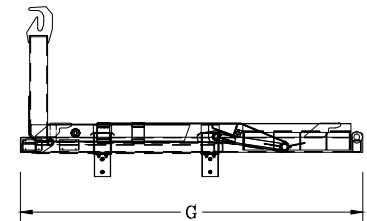
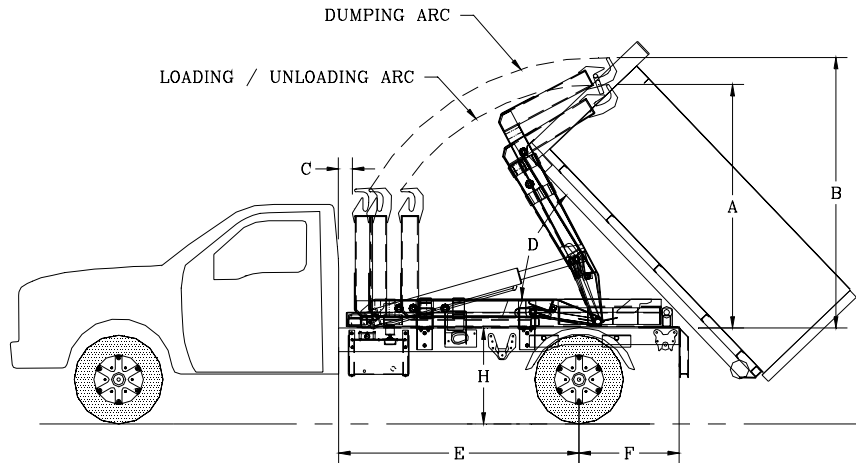

(HOOK HEIGHT & CONTAINER SPECIFICATIONS ON BACK)

HOIST MODELS	U9-HK-84	U9-HK-120
* (A) MAXIMUM HOOK HEIGHT ABOVE TRUCK FRAME LOADING / UNLOADING	85 1/16"	85 3/16"
* (B) MAXIMUM HOOK HEIGHT ABOVE TRUCK FRAME DUMPING	94 9/16"	105 3/16"
(C) CAB TO HOIST	4 15/16"	7 15/16"
(D) RAISED ANGLE	63° (9') - 51° (8' & 10')	57° (10') - 46° (12')
(E) CAB TO AXLE	84"	120"
** (F) AFTER FRAME	35"	35"
** (G) HOIST LENGTH	113 15/16"	144 13/16"
** (H) TRUCK FRAME HEIGHT	33 1/2" OR LESS	33 1/2" OR LESS
(I) HOOK HEIGHT	(SEE BACK PAGE FOR DRAWING & DIMENSIONS)	
RATED CAPACITY	9,000 LBS	9,000 LBS
LIFT CYLINDERS	5" X 3" X 45 1/4"	5" X 3" X 45 1/4"
JIB CYLINDER	3" X 2" X 16 1/4"	3" X 2" X 28 1/8"
HOOK HEIGHT	35"	35"
RECOMMENDED CONTAINER LENGTH	8' - 10'	10' - 12'

(1) FACTORY TESTED WITH RECOMMENDED CONTAINER LENGTH AND WATER LEVEL LOAD.

(2) WHEN RECOMMENDING CONTAINER LENGTHS; WEIGHT DISTRIBUTION, DUMP ANGLE, AND OVERHANG ARE FACTORS.

* TOTAL MAXIMUM HEIGHT WILL DEPEND ON CONTAINER. CONSULT ENGINEERING FOR CLEARANCE

** CONSULT ENGINEERING FOR BEST CONFIGURATION

MODEL U9

HOIST FRAME	STRUCTURAL TUBING 62,000 LBS. MIN TENSILE A500 GRADE C
JIB FRAME	A514 T-1 100,000 PSI MINIMUM YIELD
PIVOT TUBE	A514 T-1 100,000 PSI MINIMUM YIELD
PICKUP HOOK	A514 T-1 100,000 PSI MINIMUM YIELD
LIFT CYLINDER PINS	1 1/2" SOLID
HINGE SHAFT	2" SOLID WITH OUTBOARD SUPPORTED UPPER LIFT SHAFTS
REAR HOLD DOWN	1/2" PLATE
OPERATING PRESSURE	3500 PSI
HYDRAULIC PUMP	GEAR TYPE - 6.8 G.P.M. - 1500 RPM (Automatic Transmission) GEAR TYPE - 17.5 G.P.M. - 1500 RPM (Manual Transmission)
HYDRAULIC VALVE	2 SPOOL SECTIONAL VALVE WITH SAFETY BY-PASS
OIL RESERVOIR	13 GALLON WITH 10 MICRON AIR BREATHER 25 MICRON IN TANK RETURN FILTER
WORKING POINTS	GREASEABLE

CONTAINER SPECIFICATIONS

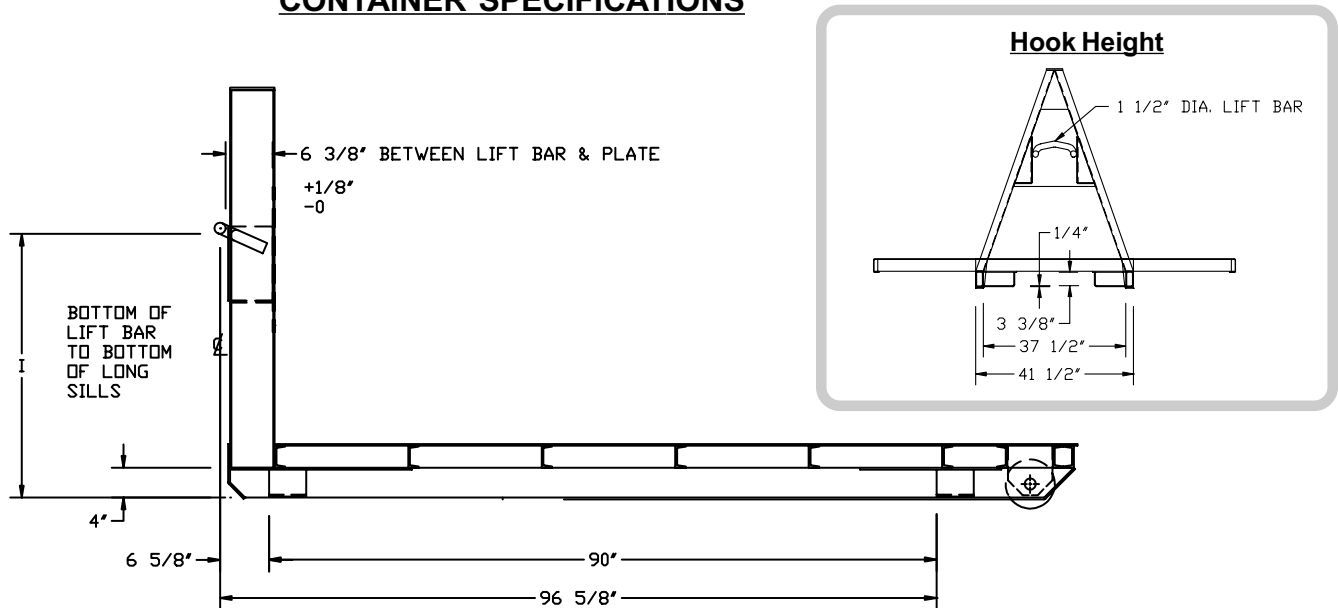

HOIST MODELS	U9-HK-84	U9-HK-120
(H) HOOK HEIGHT	35 1/2" - 35 5/8"	35 1/2" - 35 5/8"

CYCLE TIMES AT APPROXIMATELY 17.5 GPM

LIFT CYLINDER
 EXTENDING DUMP - 26.37 SECONDS
 RETRACTING DUMP - 16.88 SECONDS

JIB CYLINDER
 EXTENDING JIB - 4 SECONDS
 RETRACTING JIB - 2 SECONDS

THE GALBREATH 9,000 LB. HOOK HOIST IS AVAILABLE FOR EITHER A 84" OR 120" CHASSIS.

MINIMUM TRUCK SPECIFICATIONS

FRONT AXLE: 6,000 LBS. (WITH POWER STEERING)
REAR AXLE: 12,000 LBS.