



GALBREATH INCORPORATED
 Corporate Headquarters
 461 E. Rosser Drive, P.O. Box 220
 Winamac, IN 46996
 Ph: 574-946-6631 Fax: 574-946-4579
 800-285-0666 (Inside USA)

P.O. Box 53004
 Grand Prairie, TX 75053-0004
 Ph: 817-477-4564 Fax: 817-473-7657
 800-297-0668 (Inside USA)

Highway 75 South, Route #1
 Ider, AL 35981
 Ph: 256-657-6140 Fax: 256-657-6147
 800-964-6478 (Inside USA)

GENUINE ALL STAR PARTS
 800-946-9476 Fax: 574-946-4257

<http://www.galbreath-inc.com>

GP350 3 Cu. Yd. Stationary Compactor

MODEL NUMBER		GP350
WASTEC Rating Size		2.54 cu. yd.
Clear Top Opening -	Length	67"
	Width	57"
Ram Penetration		18"
Chamber Length		70-1/2"
Ram Face -	Height	28"
	Width	60"
Cylinder Stroke		90"
Cylinder Bore		6"
Cylinder Rod Diameter		4-1/2"
Discharge Opening -	Height	42-1/2"
	Width	61-1/2"
Ground Height		16"
Scale Weight	Approx.	6,400 lbs.
Cycle Time		50.8 sec.
Pump Size		13 GPM
Motor Size		15 HP
Operating Pressure -	Normal	1950 PSI
	Maximum	2250 PSI
Force Rating -	Normal	32.8/55,100
	Maximum	37.9/63,600
Chamber Sides		1/4" Plate
Chamber Floor		1/2" AR Plate
Ram Top		1/4" Plate
Ram Sides		1/4" Plate
Ram Floor		1/4" Plate
Ram Face		1/2" Plate
Top Cover	Smooth Plate	12 Ga.
Volume Displacement Rate		180 cu. yd. per hr.

- ### STANDARD FEATURES
- Solid State Control System
 - External Power Plant
 - UL & Canadian UL Listed Industrial Control Panel
 - 15 HP, 208/230/460 Volt, 3 Phase Continuous Duty Motor
 - 37 Gallon Capacity Oil Tank
 - 40 Micron Air Filter
 - 200 Mesh Suction Filter in Reservoir
 - Oil Level Sight Gauge with Thermometer
 - 40 GPM Regenerative Hydraulic Control Valve
 - 3/4 Full Light (1550 PSI)
 - Container Full Light (1950 PSI)
 - Hold to Operate Mode
 - Hold to Operate Extend/Auto Retract Mode
 - 2 - 8 Multicycle Modes
 - Ram Stop Extended Mode
 - Operator's Controls on 15' Flexible Conduit
 - Claw Type Grab Hooks
 - Replaceable Nylon Ram Guides
 - 2 Year Limited Warranty

- ### OPTIONAL FEATURES
- Internal Power Plant
 - Electro-Mechanical Power Plant
 - Weather cover for Power Plant
 - Pressure Gauge
 - 500 Watt Oil Heater
 - Photoelectric Eye
 - Low Oil/High Temperature Shut Off Sensor
 - Interlock Switch On 30' Flexible Conduit
 - Hauler's Controls on 15' Flexible Conduit
 - Hoppers
 - Drive-On Deck
 - Chutes
 - 20 HP With 16 GPM Power Plant
 - Finish Paint Any Standard Galbreath Color



Compactors

MODEL GP350 STATIONARY COMPACTOR

70 9/16"
80 5/8"

32 3/4"

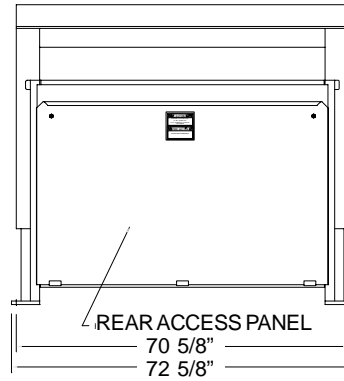

72 5/8"
FRONT

REAR

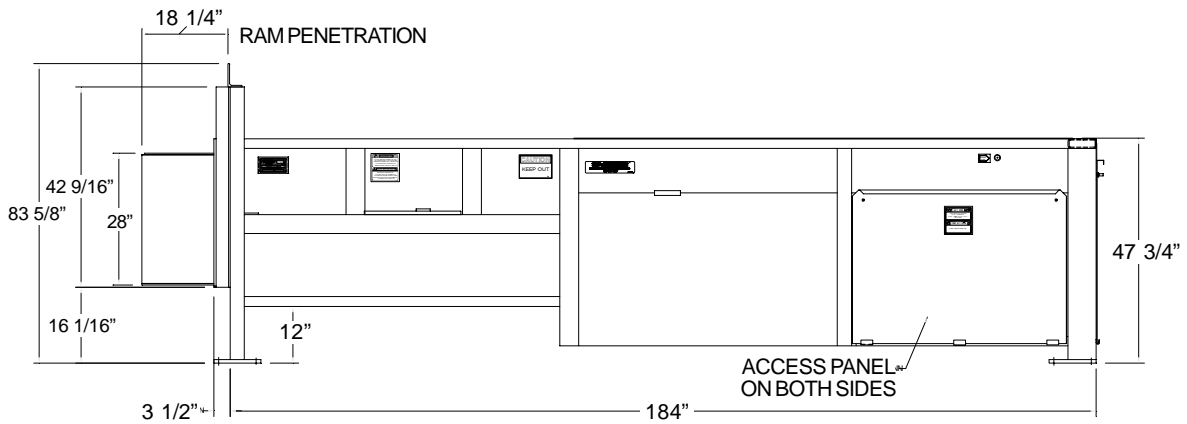

SIDE

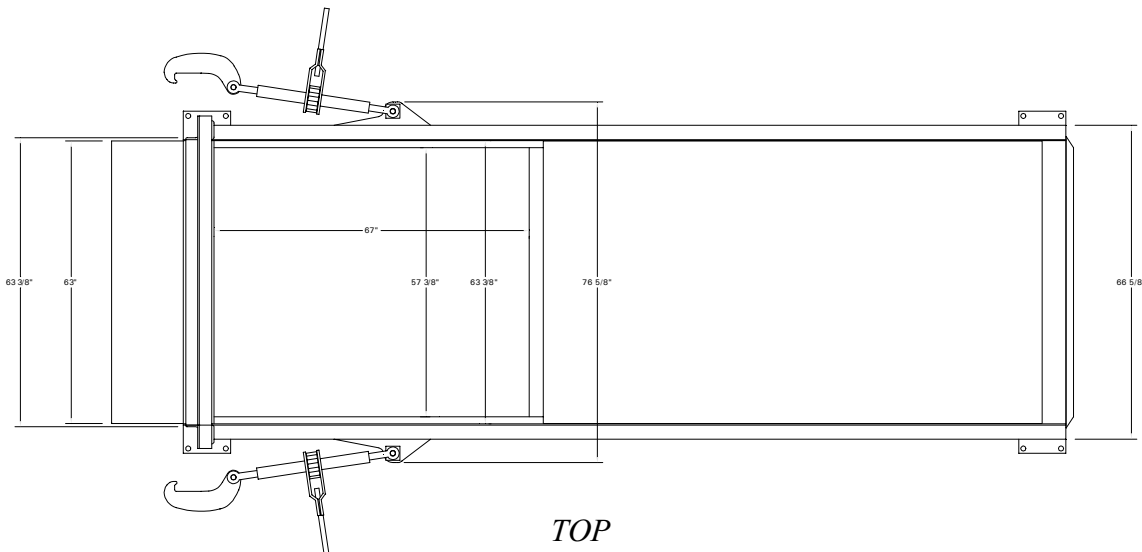

TOP